

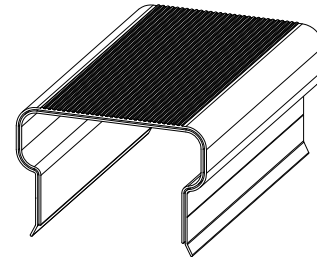

# AW-575 STR Cap



Drawn: JAB      Date: 06/18/09

<b>Section Modulus (Z)</b>	5.7 in <sup>3</sup>	93 cm <sup>3</sup>
<b>Moment of Inertia (I)</b>	21 in <sup>4</sup>	874 cm <sup>4</sup>
<b>Outside Width</b>	7.4 in	188 mm
<b>Inside Width</b>	5.5 in	140 mm
<b>Material</b>	6063-T6 Marine Grade Aluminum	
<b>Sheet Piling Compatibility</b>	SG-225, CL-4500, GG-20	
<b>Tie Rod Compatibility</b>	AW 1.5" x 0.75" Rod Kit	
<b>Recommended Accessories</b>	Beveled PVC Washer, 45° and 90° AW-575 Corner Insert	
<b>Standard Colors/Surface Treatment</b>	Mill Finish, Grey, Clay, Anodized Marine Bronze	
<b>Standard Packaging</b>	20ft AW-575 Cap, SS and PVC Fasteners, 20ft Structural Insert	

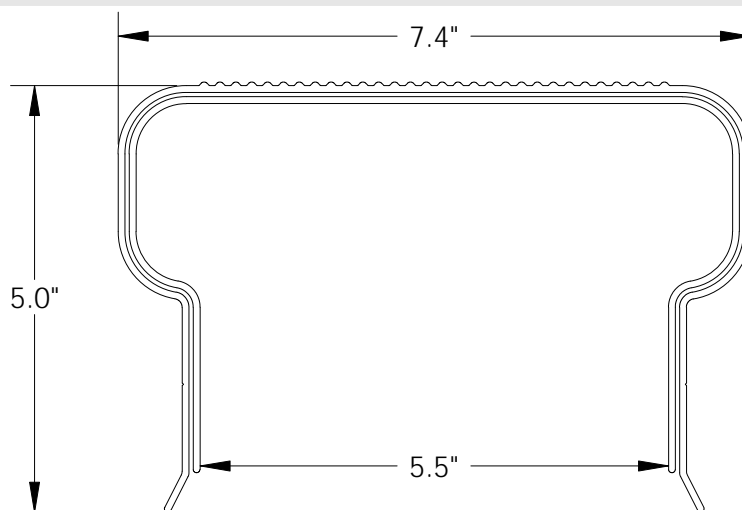

Physical properties are defined by ASTM testing standards, The Aluminum Association Design Manual, and/or standard engineering practice. The values shown are nominal and may vary. The information found in this document is believed to be true and accurate. No warranties of any kind are made as to the suitability of any CMI product for particular applications or the results obtained there from. ShoreGuard, C-Loc, TimberGuard, GeoGuard, Dura Dock, Shore-All, and Gator Gates are registered trademarks of Crane Materials International. ArmorWare, Ultra Composite, GatorDocks, GatorBridge and CMI Waterfront Solutions are trademarks of Crane Materials International. United States and International Patent numbers 5,145,287; 6,000,883; 6,033,155; 6,053,666; D420,154; 6,575,667; 7,059,807; 7,056,066; 7,025,539; 7,393,482; Other patents pending. © 2009 Crane Materials International. All Rights Reserved.